



CYBERINFRASTRUCTURE INTEGRATION RESEARCH CENTER

PERVASIVE TECHNOLOGY INSTITUTE

Cluster Frameworks and Kubernetes

March 11th 2021

Suresh Marru & Marlon Pierce

Reference Papers

- Verma, Abhishek, Luis Pedrosa, Madhukar Korupolu, David Oppenheimer, Eric Tune, and John Wilkes. "Large-scale cluster management at Google with Borg." In *Proceedings of the Tenth European Conference on Computer Systems*, pp. 1-17. 2015.
 - <https://dl.acm.org/doi/pdf/10.1145/2741948.2741964>
- Burns, Brendan, Brian Grant, David Oppenheimer, Eric Brewer, and John Wilkes. "Borg, omega, and kubernetes." *Queue* 14, no. 1 (2016): 70-93.
 - <https://dl.acm.org/doi/pdf/10.1145/2898442.2898444>
 - The lecture borrows concepts and content from this paper.

Cluster Computing Frameworks





Google™

Pregel



Pig

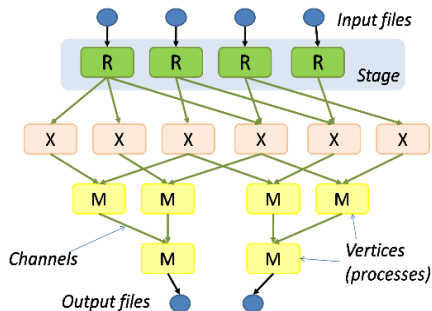

Dryad



CIEL

Google™

Percolator

S4 distributed stream
computing platform



Container recap

- “Containers encapsulate the application environment, abstracting away many details of machines and operating systems from the application developer and the deployment infrastructure.”
- “Because well-designed containers and container images are scoped to a single application, managing containers means managing applications rather than machines. This shift of management APIs from machine-oriented to application oriented dramatically improves application deployment and introspection.”

The Challenge

Multiplicity of Stacks



Static website

nginx 1.5 + modsecurity + openssl + bootstrap 2



Background workers

Python 3.0 + celery + pyredis + libcurl + ffmpeg + libopencv + nodejs + phantomjs



User DB

postgresql + pgv8 + v8



Queue

Redis + redis-sentinel



Analytics DB

hadoop + hive + thrift + OpenJDK



Web frontend

Ruby + Rails + sass + Unicorn



API endpoint

Python 2.7 + Flask + pyredis + celery + pycopg + postgresql-client

Do services and apps
Interact appropriately?

Multiplicity of
hardware
environments



Development VM



QA server

Customer Data Center

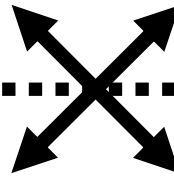

Public Cloud

Disaster recovery

Production Servers

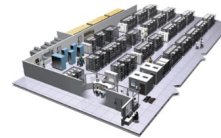

Production Cluster









Contributor's laptop



Can I migrate smoothly
and quickly?

The Matrix From Hell

	Static website	?	?	?	?	?	?	?
	Web frontend	?	?	?	?	?	?	?
	Background workers	?	?	?	?	?	?	?
	User DB	?	?	?	?	?	?	?
	Analytics DB	?	?	?	?	?	?	?
	Queue	?	?	?	?	?	?	?
		Development VM	QA Server	Single Prod Server	Onsite Cluster	Public Cloud	Contributor's laptop	Customer Servers



Cargo Transport Pre-1960

Multiplicity of Goods

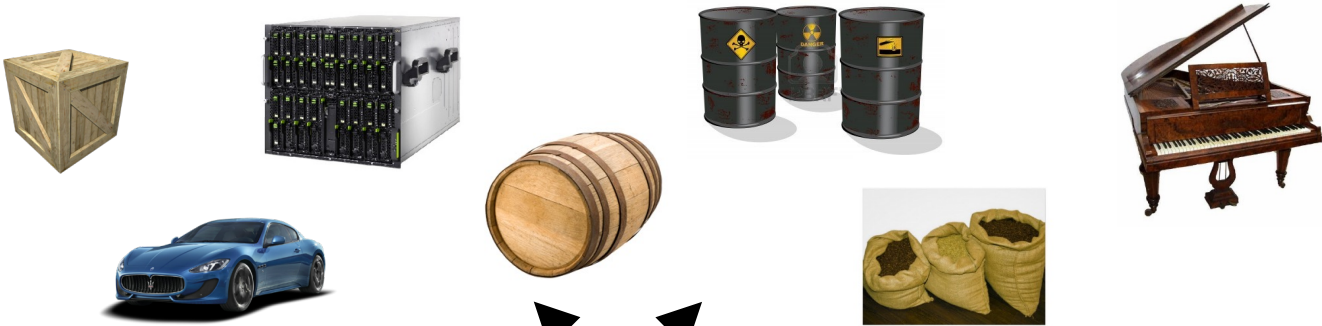





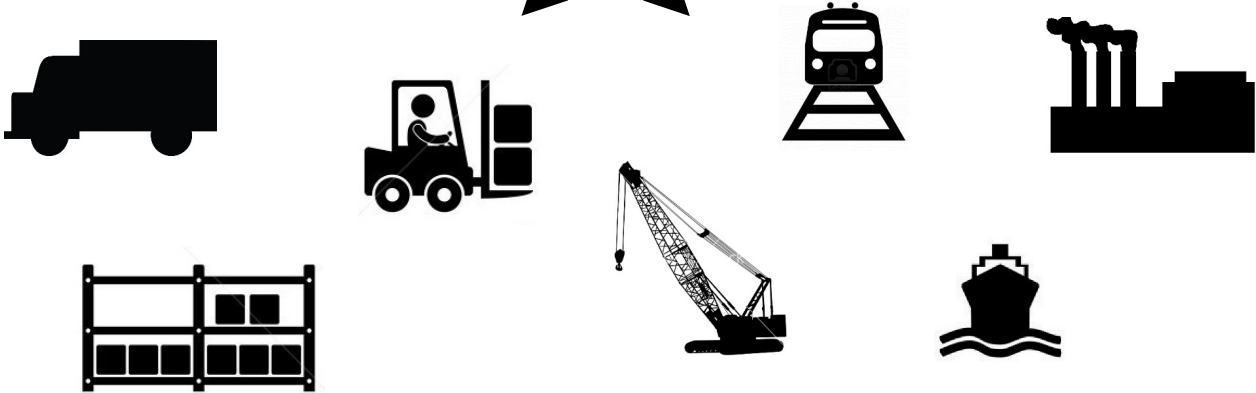







Do I worry about how goods interact (e.g. coffee beans next to spices)

Multiplicity of methods for transporting/storing



Can I transport quickly and smoothly (e.g. from boat to train to truck)

A matrix from hell

	?	?	?	?	?	?	?
	?	?	?	?	?	?	?
	?	?	?	?	?	?	?
	?	?	?	?	?	?	?
	?	?	?	?	?	?	?
	?	?	?	?	?	?	?
							

Solution: Intermodal Shipping Container

Multiplicity of Goods



A standard container that is loaded with virtually any goods, and stays sealed until it reaches final delivery.



...in between, can be loaded and unloaded, stacked, transported efficiently over long distances, and transferred from one mode of transport to another

Multiplicity of methods for transporting/storing

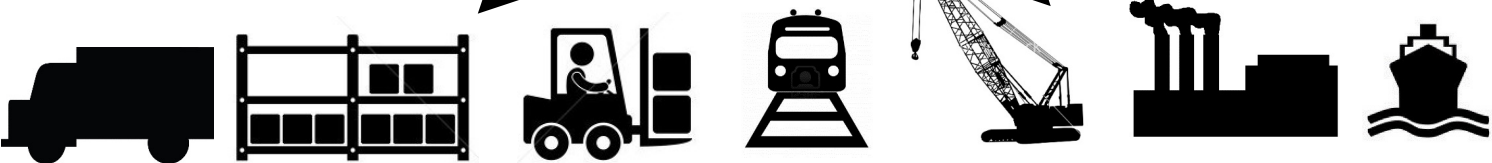

Do I worry about how goods interact (e.g. coffee beans next to spices)

Can I transport quickly and smoothly (e.g. from boat to train to truck)

Docker is a shipping container system for code

Multiplicity of Stacks

Static website User DB Web frontend Queue Analytics DB

An engine that enables any payload to be encapsulated as a lightweight, portable, self-sufficient container...



...that can be manipulated using standard operations and run consistently on virtually any hardware platform

Multiplicity of hardware environments

Development VM QA server Customer Data Center Public Cloud Production Cluster Contributor's laptop

Do services and apps interact appropriately?

Can I migrate smoothly and quickly

Docker: Infrastructure as Code

- In short, Docker lets you define in script files everything about each of your microservices.
- Combine this with CI/CD systems to deploy EACH microservice.
 - Your development to test to production environments should be identical and reproducible.
 - Testing and production deployments for each service should be infinitely clone-able.
- This is not elasticity, but it is a prerequisite.
- Docker and other containers have much less overhead

Changes and Update

<https://docs.docker.com/storage/storagedriver/>

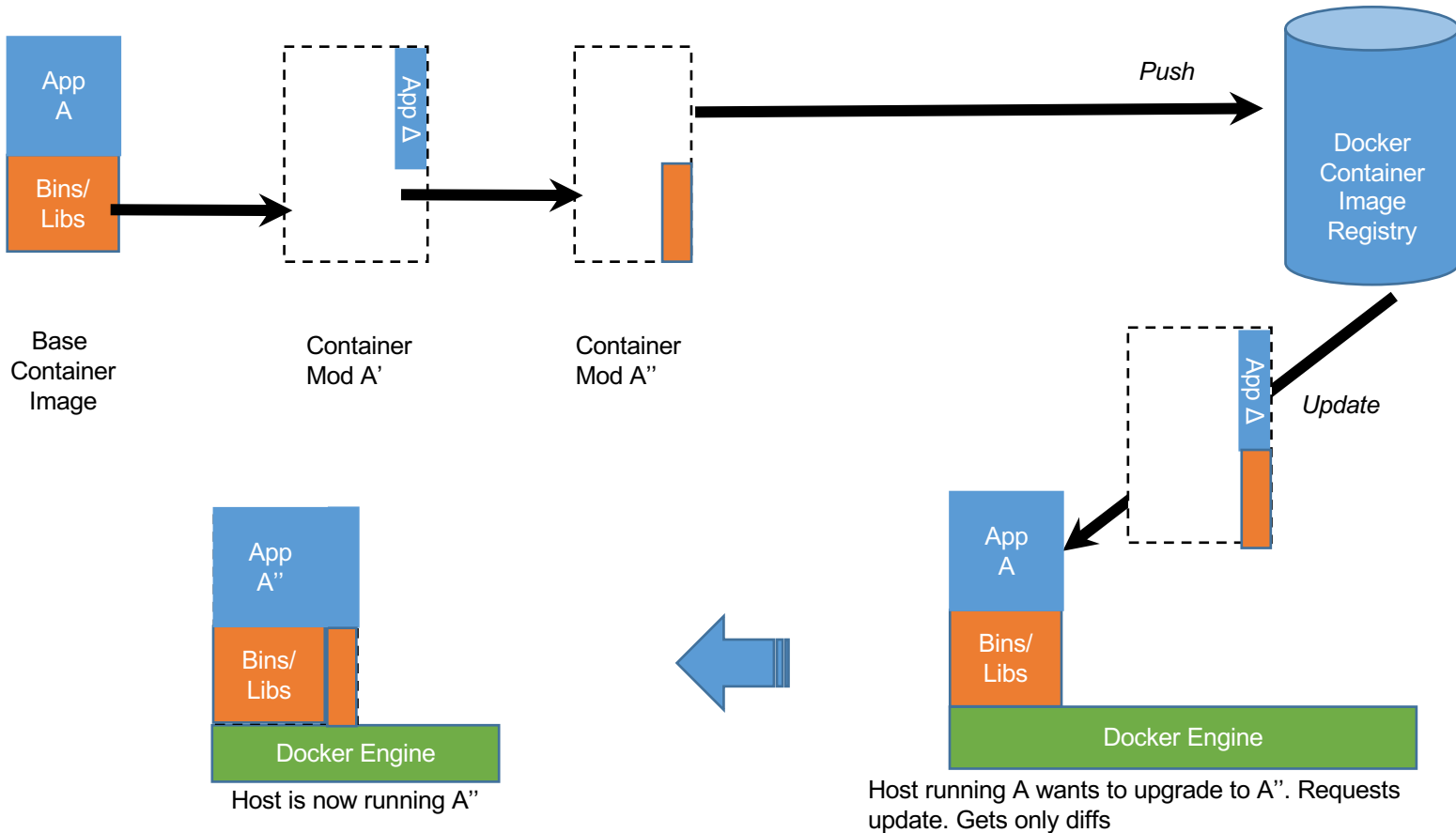

Cloud Federation

Docker Swarm (Cluster Federation)

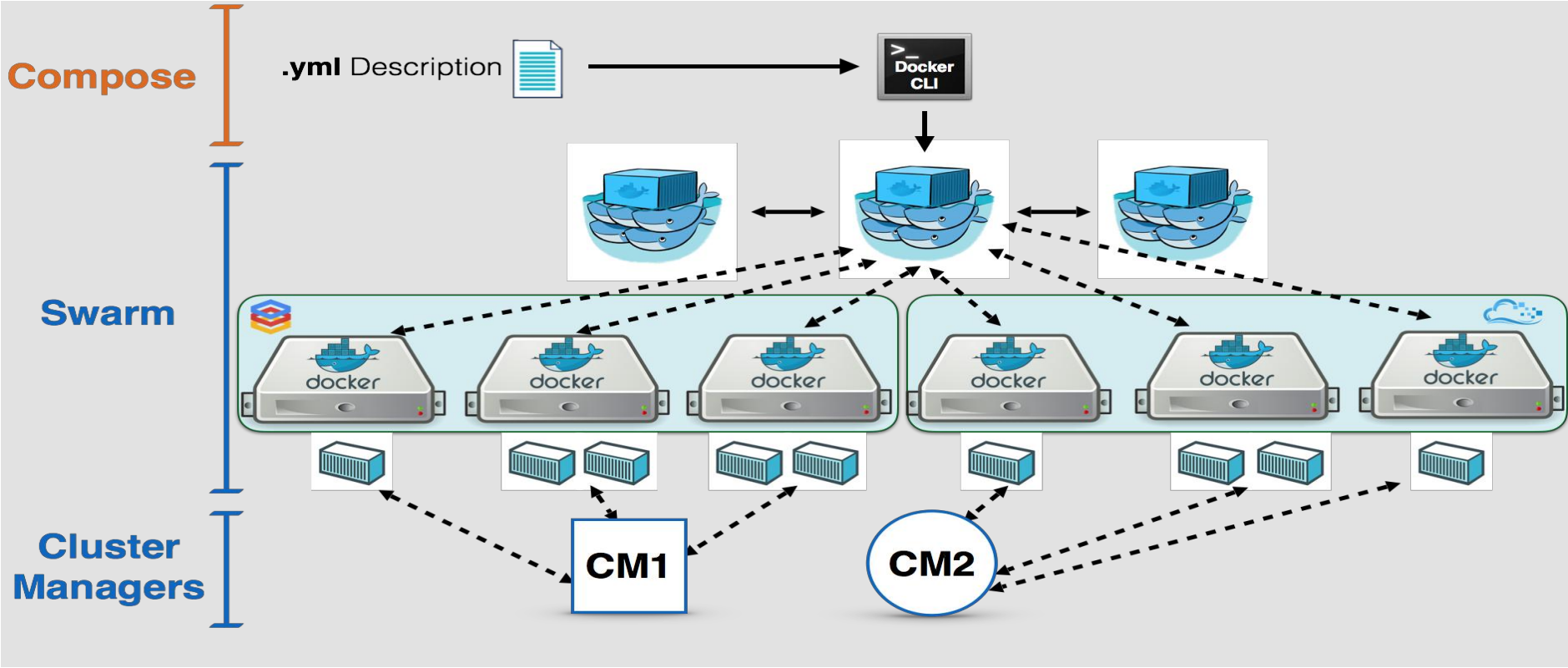

Cloud Federation

Ubernetes (Google)

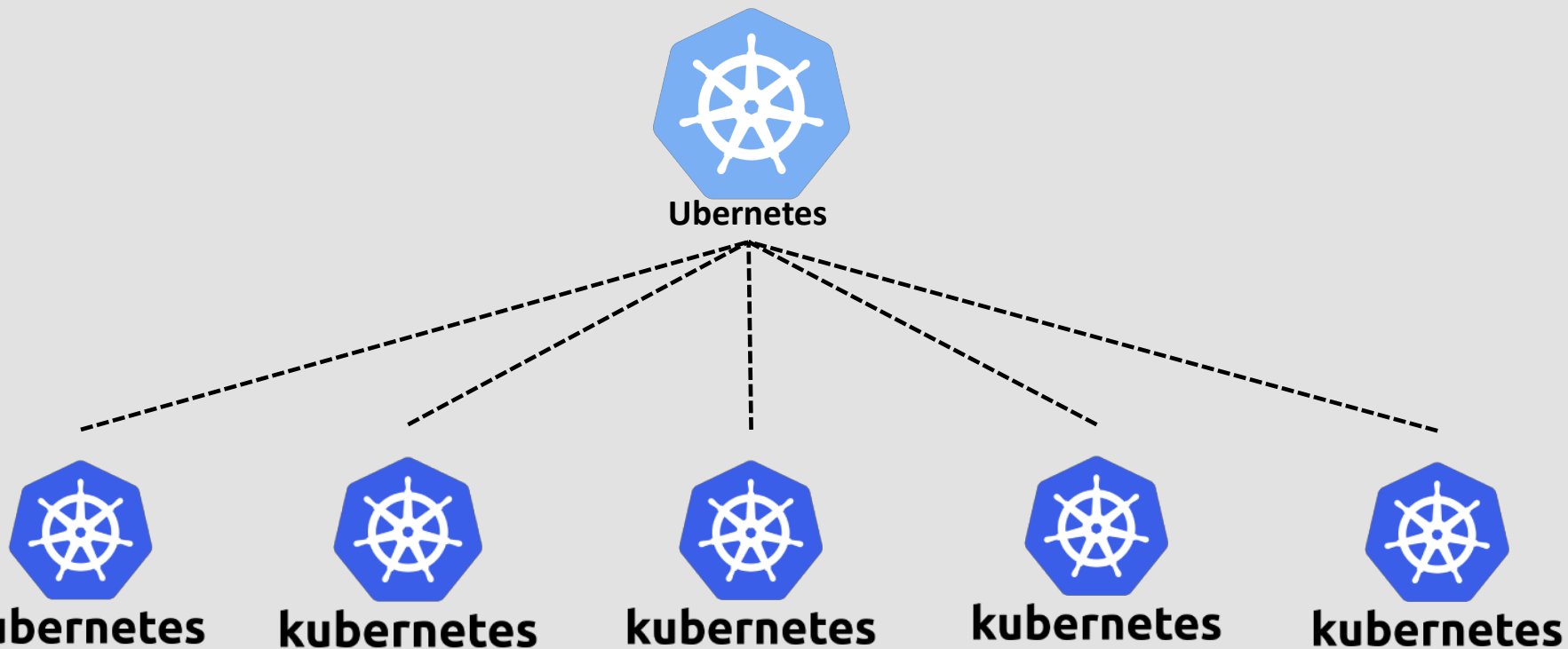

Google Borg

- Borg: An OS of Cluster (Datacenter)
- Motivation
 - Hide the details (programmer focus on App)
 - Provide resource sharing
 - Provide high reliability and availability for Cluster

The User Perspective

```
job hello_world = {  
  runtime = { cell = 'ic' }           // What cluster should we run in?  
  binary = '../hello_world_webserver' // What program are we to run?  
  args = { port = '%port%' }         // Command line parameters  
  requirements = {                    // Resource requirements  
    ram = 100M  
    disk = 100M  
    cpu = 0.1  
  }  
  replicas = 10000 // Number of tasks  
}
```

> borgcfg ../hello_world_webserver.borg up

The User Perspective

- Allocs
 - Reserved set of resources
- Priority, Quota, and Admission Control
 - Job has a priority (preempting)
 - Quota is used to decide which jobs to admit for scheduling
- Naming and Monitoring
 - `50.jfoo.ubar.cc.borg.google.com`
 - Monitoring health of the task and thousands of performance metrics

Borg Architecture

- Borgmaster
 - Main Borgmaster process & Scheduler
 - Five replicas
- Borglet
 - Manage and monitor tasks and resource
 - Borgmaster polls Borglet every few seconds

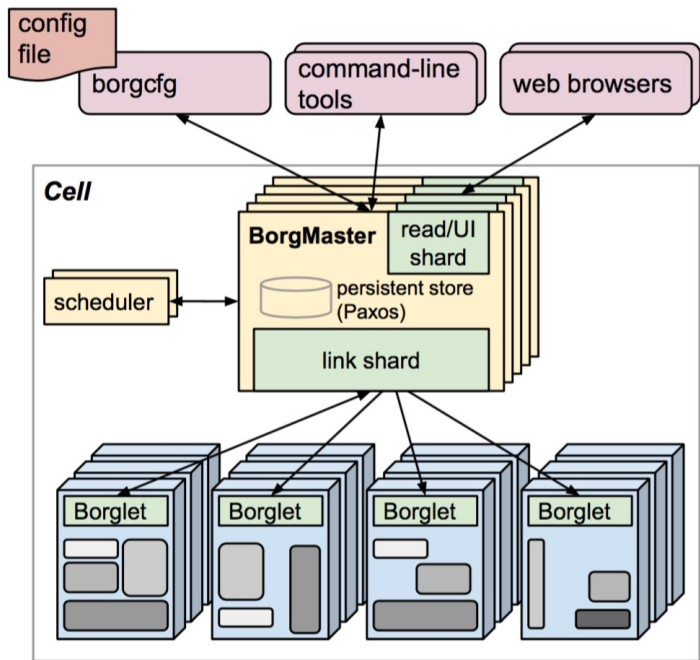

The high-level architecture of Borg(A Cell)

Borg Architecture

- Scheduling
 - feasibility checking: find machines
 - Scoring: pick one machines
 - User preferences & build-in criteria
 - E-PVM VS best-fit
 - Tradeoff

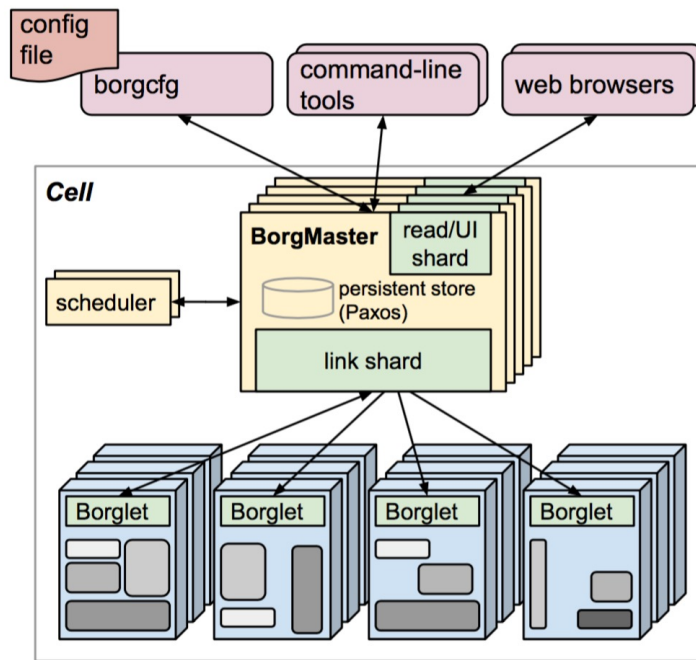

The high-level architecture of Borg(A Cell)

Scalability

- Separate scheduler
- Separate threads to poll the Borglets
- Partition functions across the five replicas
- Score caching
- Equivalence classes
- Relaxed randomization

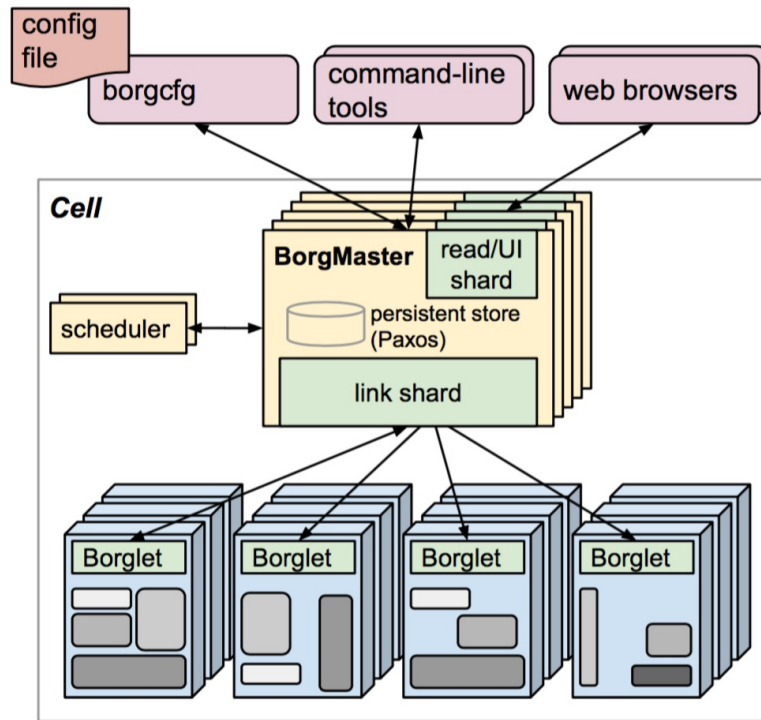

The high-level architecture of Borg(A Cell)

Availability

- System

- Borgmaster:
- Borglet: Borgmaster
- Take checkpoint

- Job

- Reschedules evicted tasks
- Spreading tasks across failure domains
- ...

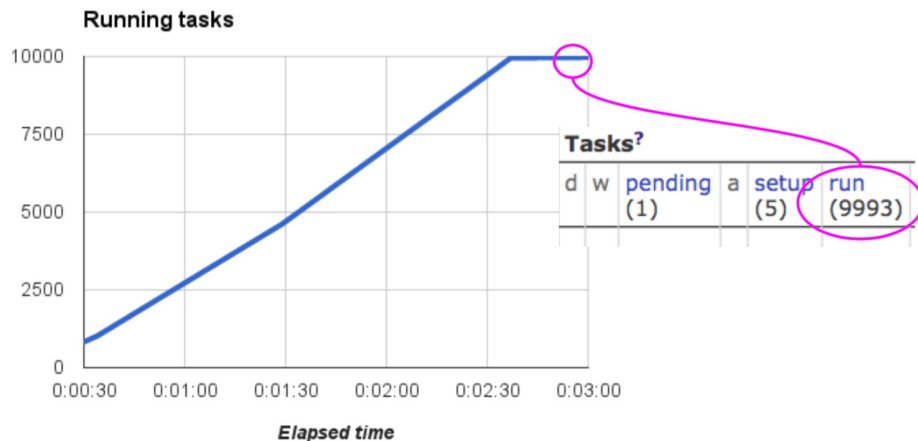
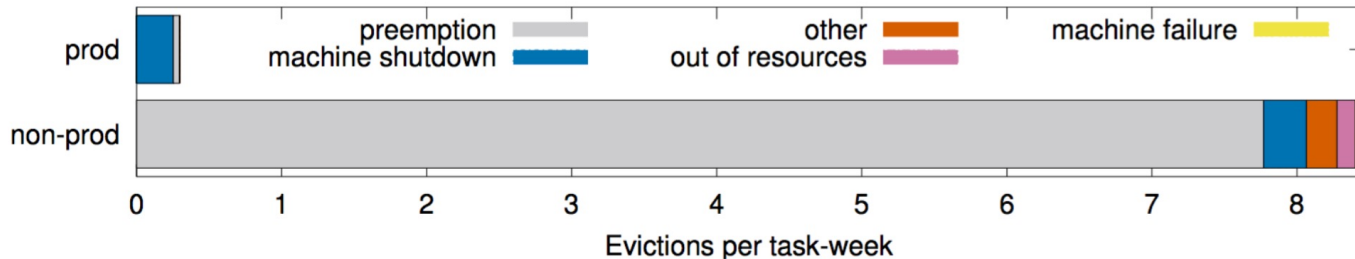

Utilization

- Cell Sharing
 - Segregating prod and non-prod work into different cells would need more machines

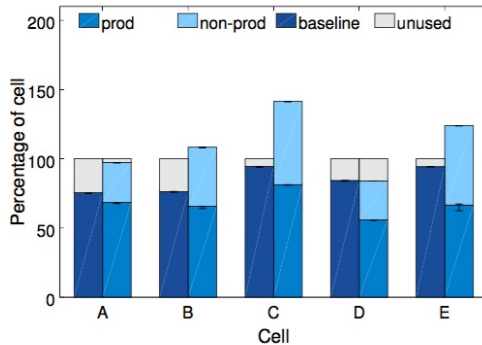

(a) The left column for each cell shows the original size and the combined workload; the right one shows the segregated case.

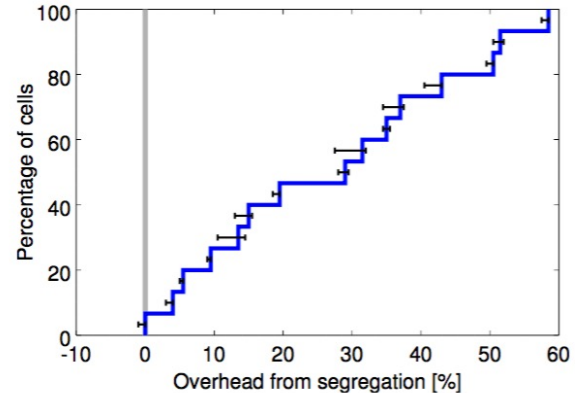

(b) CDF of additional machines that would be needed if we segregated the workload of 15 representative cells.

Utilization

- Cell Size
 - Subdividing cells into smaller ones would require more machines

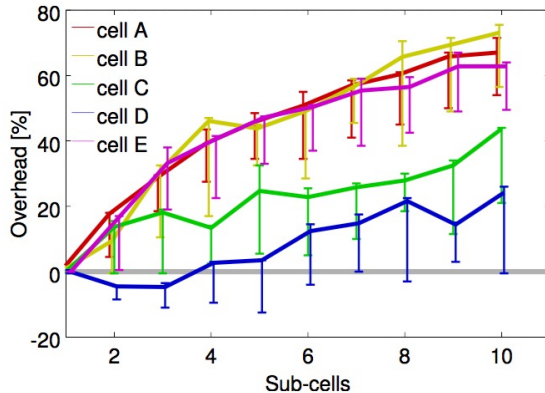

(a) Additional machines that would be needed as a function of the number of smaller cells for five different original cells.

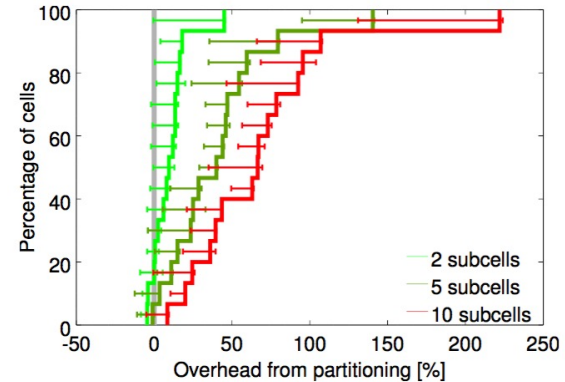

(b) A CDF of additional machines that would be needed to divide each of 15 different cells into 2, 5 or 10 cells.

Utilization

- Fine-grained resource requests

No bucket sizes fit most of the tasks well Bucketting resource would need more machines

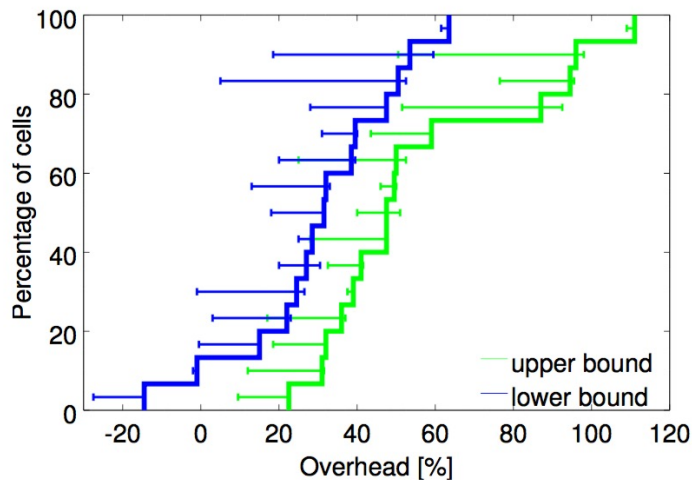
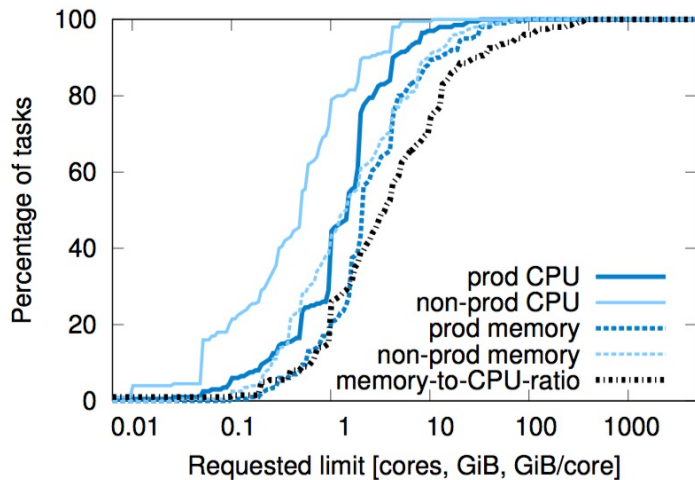

Utilization

- Resource reclamation
 - estimate how many resources a task will use and reclaim the rest for work
 - Kill non-prod if not available

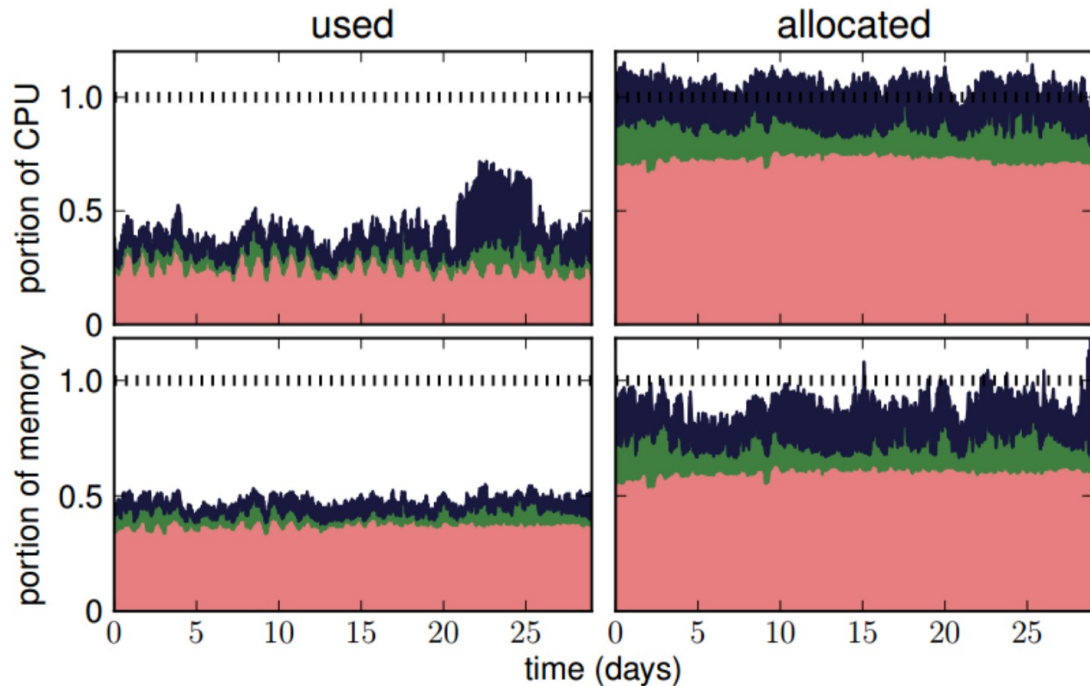

Utilization

- Resource reclamation
 - Choose medium

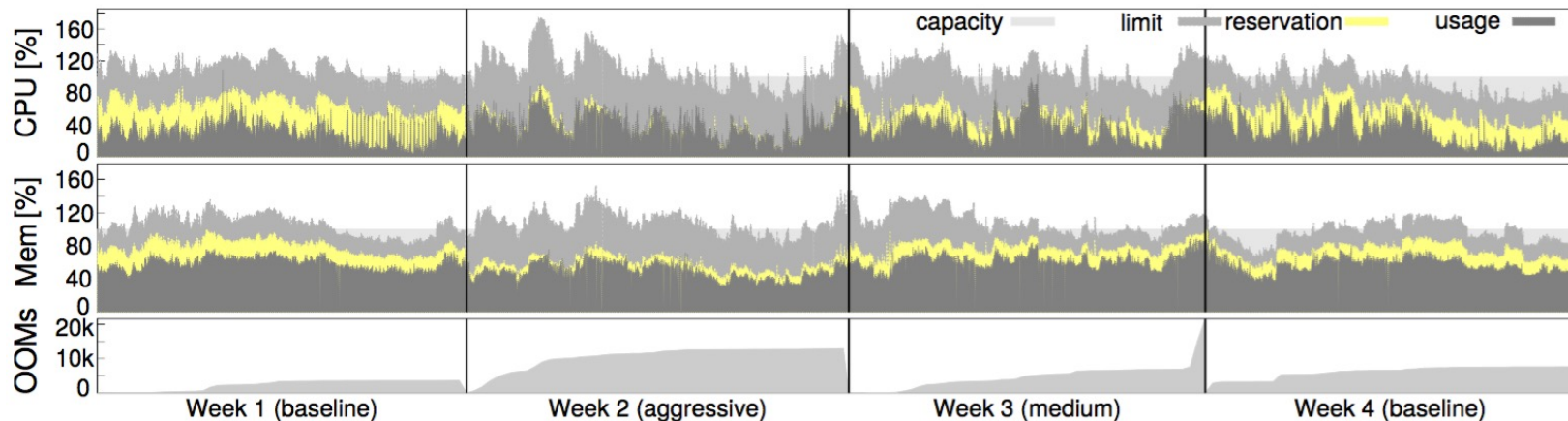

Isolation

- Security isolation
 - chroot jail as the primary security isolation mechanism
- Performance isolation
 - High-priority LV task(prod) get best treatment
 - compressible resources: reclaimed
 - non-compressible resources: kill or remove task

Kubernetes

- Evolved from Borg
- An open-source system for automating deployment, operations, and scaling of containerized applications
- Pods: groups of containers
- Labels
- Replica controller
- Services

